

# Pesticides: Test Tube to Warehouse



# Table of Contents

- ***Research & Development***
  - ***Active***
  - ***Formulation & Packaging***
  - ***Application***
- ***Manufacturing***
  - ***Active***
  - ***Co-formulants***
  - ***Formulation***
  - ***Packaging***



# Pesticides

Pesticides: Substances or mixture of substances intended for preventing, destroying, repelling or mitigating any pest

- Herbicides: Type of pesticide used to kill unwanted plants
- Insecticides: Type of pesticide used against insects
- Fungicides: Type of pesticide used to kill or inhibit fungi or fungal spores
- Nematicides: Type of pesticide used to kill parasitic nematodes

In agriculture, an active ingredient (AI) is a molecule that has good biological activity against pests, weeds, or diseases that impact the end user.



# Insecticide

**Group 1: Acetylcholinesterase (AChE) inhibitors** (overrepresentation of pyrethroids)

1A Carbamates

1B Organophosphates

**Group 2: GABA-gated chloride channel antagonists**

2A Cyclopyridone Organochlorines

2B Phenylpyrazoles (Fipronil)

**Group 3: Sodium channel modulators** (overrepresentation of pyrethroids)

3A Pyrethroids  
Pyrethrin

3B DDT, Methoxychlor

**Group 4: Nicotinic acetylcholine receptor (nAChR) agonists**

4A Neonicotinoids

4B Nicotine

**Group 5: Nicotinic acetylcholine receptor (nAChR) allosteric modulators**

5 Spirochens

**Group 6: Chloride channel activators**

6 Avermectins, Milbemycins

**Group 7: Juvenile hormone analogs**

7A Juvenile hormone analogues

7B Fenoxycarb

7C Pyriproxyfen

**Mode of Action Classification**

# IRAC

**Insecticide Resistance Action Committee**

**The Key to Resistance Management**

More information on IRAC and the Mode of Action Classification is available from: [www.irac-online.org](http://www.irac-online.org) or [enquiries@irac-online.org](mailto:enquiries@irac-online.org)

**Group 8: Microtubule non-specific (multi-ubiq) inhibitors**

8A Alkyl halides

8B Chlorobirch

8C Sulfonyl fluoride

8D Benzox

8E Tataric acids

**Group 9: Selective hexamerin feeding blockers**

9B Pyrimidines

9C Flonicamid

**Group 10: Mitochondrial inhibitors**

10A Clofentazine, Heptachlor

10B Clozapine

**Group 11: Mitochondrial disruption of insect mitochondrial membranes and derived toxins**

11A

11B

11C

11D

11E

11F

11G

11H

11I

11J

11K

11L

11M

11N

11O

11P

11Q

11R

11S

11T

11U

11V

11W

11X

11Y

11Z

**Group 12: Inhibitors of mitochondrial ATP synthase**

12A Difenfluron

12B Organotin insecticides

12C Propargite

12D Tetradifon

**Group 13: Disruptors of collective phosphorylation via disruption of proton gradient**

13 Pyrioxa, Dintropheno

**Group 14: Nicotinic acetylcholine receptor (nAChR) channel blockers**

14 Nitenachol analogues

**Group 15: Inhibitors of chitinase synthesis, type 1**

15 Benzoxazines

**Group 16: Inhibitors of chitinase synthesis, type 2**

16 Buprofezin

**Group 17: Shikimate pathway inhibitors**

17 Cryanexin

**Group 18: Subunit alpha agonists**

18 Dicyclohydantins

**Group 19: Octopamine receptor agonists**

19 Ambroz

**Group 20: Mitochondrial complex II electron transport inhibitors**

20A Hydramethylnon

20B Acetoprophyl

20C Fluoropyth

**Group 21: Mitochondrial complex II electron transport inhibitors**

21A METI acaricides and insecticides

21B Rotenone

**Group 22: Voltage-dependent sodium channel blockers**

22A Indoxacarb

22B Metflubenzuron

**Group 23: Inhibitors of acetyl CoA carboxylase**

23 Telenor & Telenor acid derivatives

**Group 24: Mitochondrial complex IV electron transport inhibitors**

24A Phosphite

24B Cyanide

24C Cyclopropanol

**Group 25: Synapsin receptor inhibitors**

25 Difenidol

**Group 26: Components of unknown or uncertain mode of action**

26 Difenidol

26A

26B

26C

26D

26E

26F

26G

26H

26I

26J

26K

26L

26M

26N

26O

26P

26Q

26R

26S

26T

26U

26V

26W

26X

26Y

26Z

**Guidance on the use of IRAC codes**

- Resistant pest or disease should be treated with the same mode of action.
- Resistant pest or disease should be treated with the same target site.
- Resistant pest or disease should be treated with the same chemical class.
- Are all other alternatives available? If not, use the same target site.
- Are all other alternatives available? If not, use the same chemical class.
- Are all other alternatives available? If not, use the same target site.
- Are all other alternatives available? If not, use the same chemical class.

**IRAC Code of Action Classification**

- 1-12: If there are no other alternatives, compounds may be related to diseases where cross-resistance mechanisms are known to be absent in the target population.
- 13-26: If there are no other alternatives, compounds may be related to diseases where cross-resistance mechanisms are known to be absent in the target population.

**IRAC Code of Action Classification**

- 27-30: If there are no other alternatives, compounds may be related to diseases where cross-resistance mechanisms are known to be absent in the target population.
- 31-35: If there are no other alternatives, compounds may be related to diseases where cross-resistance mechanisms are known to be absent in the target population.



# Molecule Timeline

<u>Discovery</u>			<u>Pre-Development</u>			<u>Development</u>			<u>Launch</u>		
1A	1B	1C	1	2	3	4	5	6	7	8	9

- To complete the process, it will take an agricultural chemical compound approximately 9-10 years from the time it enters Phase I of the Discovery Stage until Commercial Launch.
- This costs an average of \$256 million, according to industry figures.

# Formulation Definition

**A formulation is a way to deliver an active ingredient to a specific target site in a usable form.**

All agricultural formulations consist of

active ingredient(s)

+

inert ingredients

(Co-formulants)

# The Work Of The Formulation Chemist

Modern formulation technology is an interdisciplinary scientific subject, with special relationships to the disciplines of interfacial physics, surfactant science, and colloid chemistry.

- Formulation research
- Formulation development
- Formulation production
- Formulation storage trials
- Pesticide interactions with:
  - Plants
  - Insects
  - Mammals
  - Soil
  - Air
  - Water

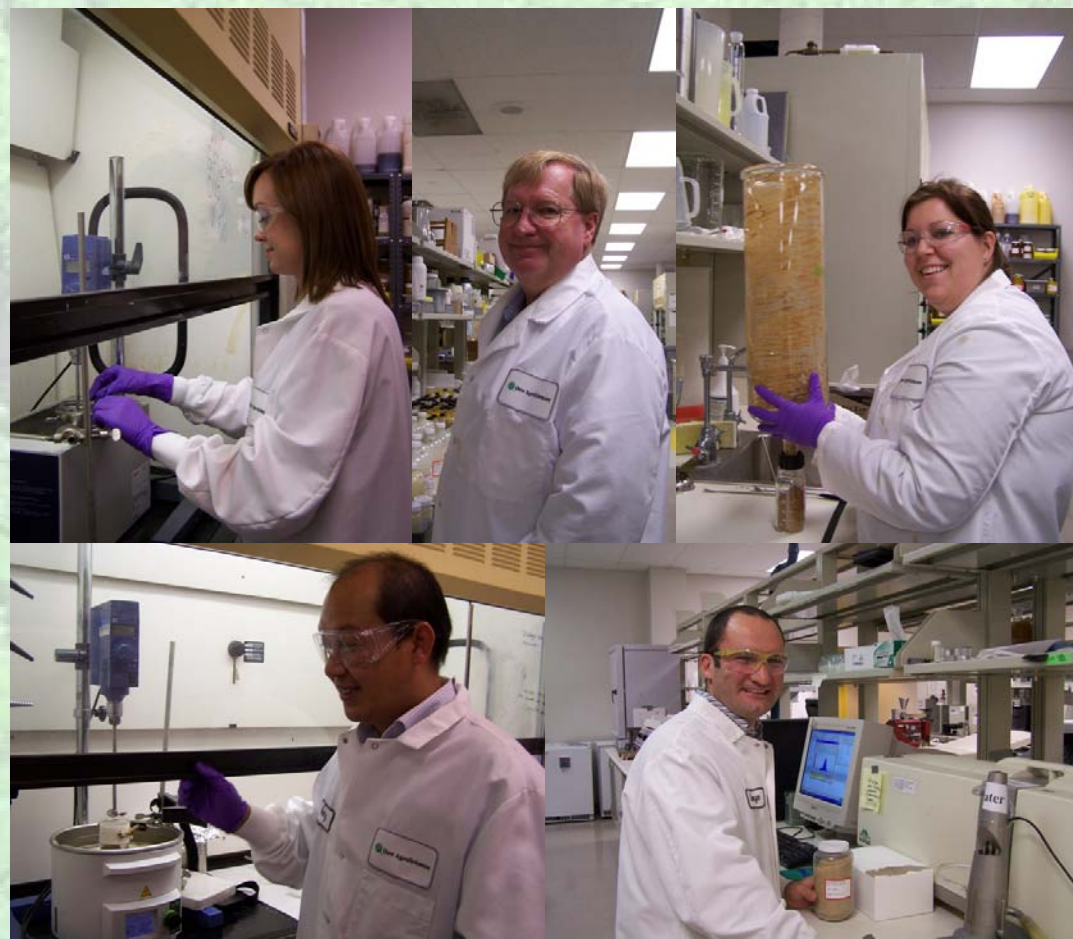

# Formulation Testing

## Global Performance Standards

- Establish standard test methods and quality criteria for all major formulation types under development
- Standards provide a minimum set of tests each formulation must pass



Rheometer

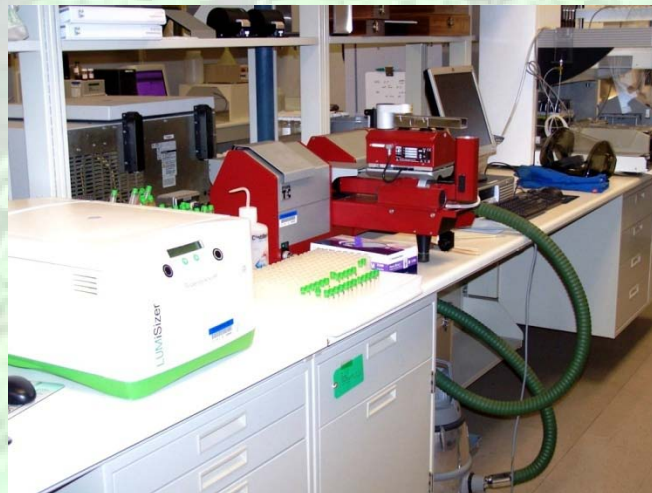

Solid particle analyzer



Particle analyzer



# Inert Ingredients (Co-Formulants)

- Surfactants
- Dry fillers and carriers
- Solvents
- Thickeners
- Biocides
- Anti-freeze
- Odorants
- Stabilizers
- Dyes and pigments

# Formulation Types

```
graph TD; A[Formulation Types] --> B[Liquid Forms]; A --> C[Solid Forms]; B --> D[Soluble Liquids (SL)]; B --> E[Suspension Concentrates (SC)]; B --> F[Emulsifiable Concentrates (EC)]; C --> G[Wettable Powders (WP)]; C --> H[Wettable Granules (WDG or WG)];
```

## Liquid Forms

**Soluble Liquids (SL)**

**Suspension Concentrates (SC)**

**Emulsifiable Concentrates (EC)**

## Solid Forms

**Wettable Powders (WP)**

**Wettable Granules (WDG or WG)**

# Liquid Formulations\*

- **CS** : **Capsule Suspension**
- **EC** : **Emulsifiable Concentrate**
- **EG** : **Emulsifiable Granule**
- **EO** : **Emulsion Water in Oil**
- **EW** : **Emulsion Oil in Water**
- **ME** : **Microemulsion**
- **OD** : **Oil Dispersion**
- **SC** : **Suspension Concentrate**
- **SE** : **Suspo-emulsion**
- **SL** : **Soluble Concentrate**

# Soluble Liquids (SL's)

- Solution of a.i. in water.
- A clear solution is formed when concentrate is diluted with water.

Aqueous solution

Dilute aqueous solution

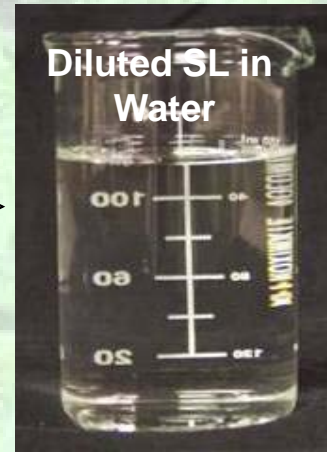
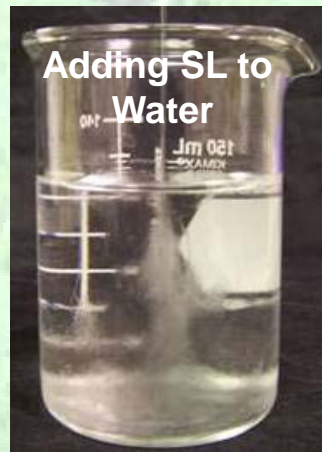
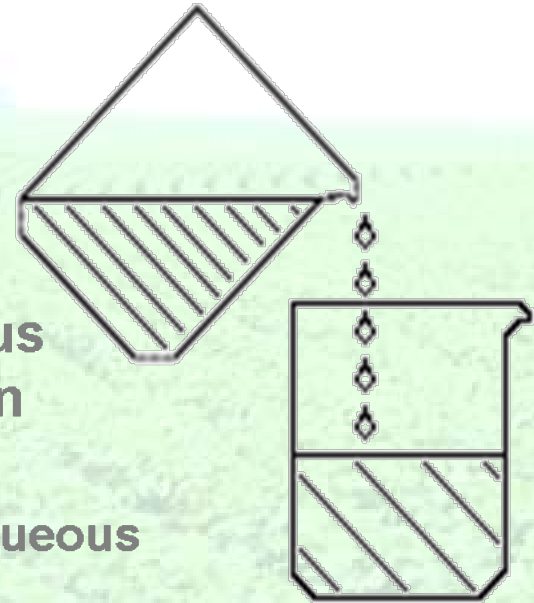

# Emulsifiable Concentrates (EC's)

- A.I. dissolved in solvent (oil) with added surfactant
- When added to water, the formulation is dispersed as small emulsified oil droplets.

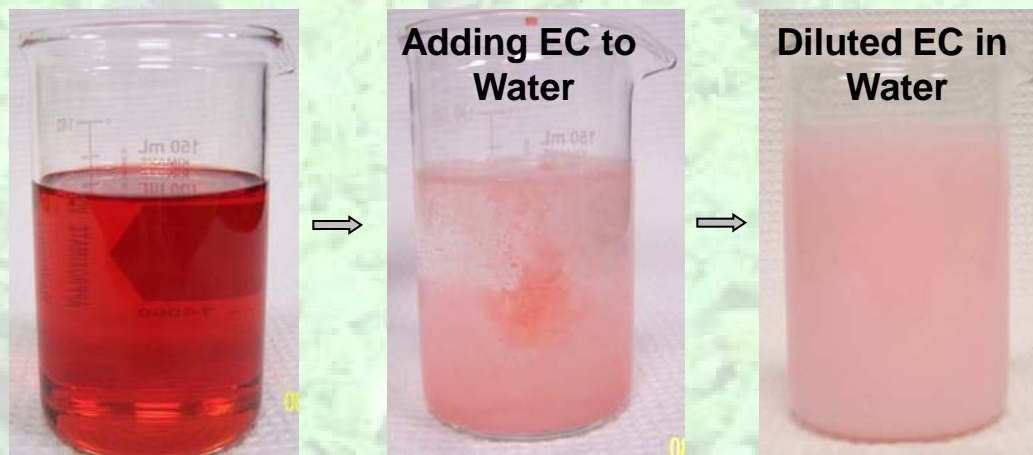
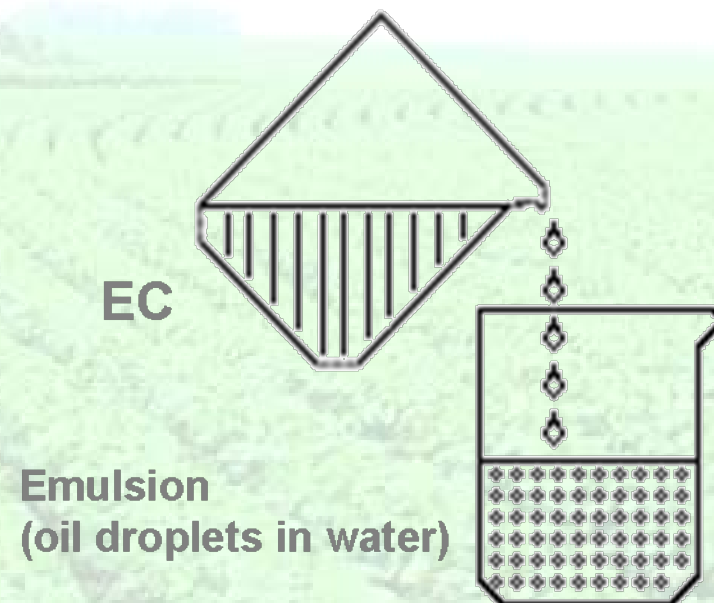

# Emulsion - Oil in Water (EW)

- Active ingredient is dissolved in oil phase with added surfactant then added to water to form a stable emulsion
- Active ingredient must be oil soluble or liquid
- Selection of surfactant critical to stability of emulsion

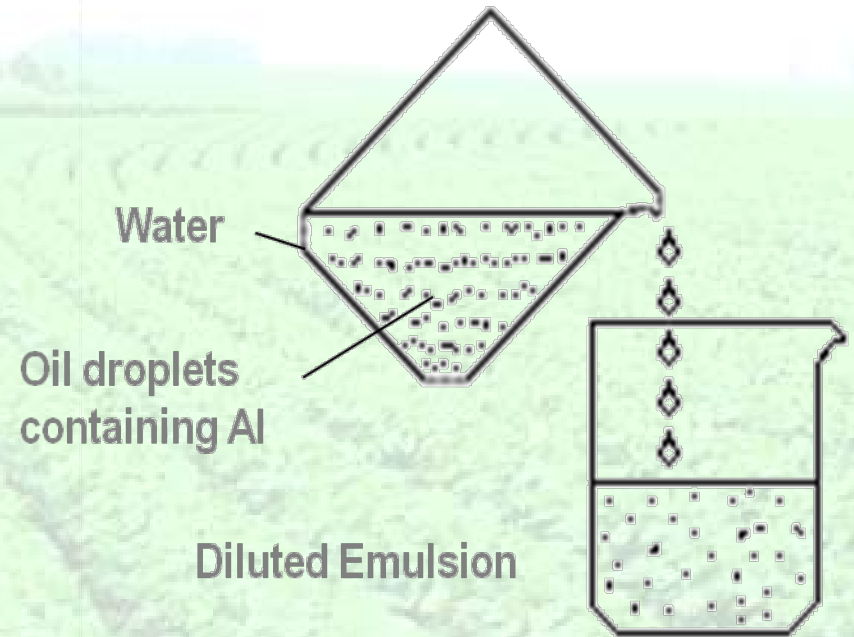

Upon stirring, SE disperses into water.



# Suspension Concentrates (SC's)

- High melting point a.i., with low water solubility, dispersed in water as small particles.
- Gels added to prevent sedimentation of a.i. particles on storage.

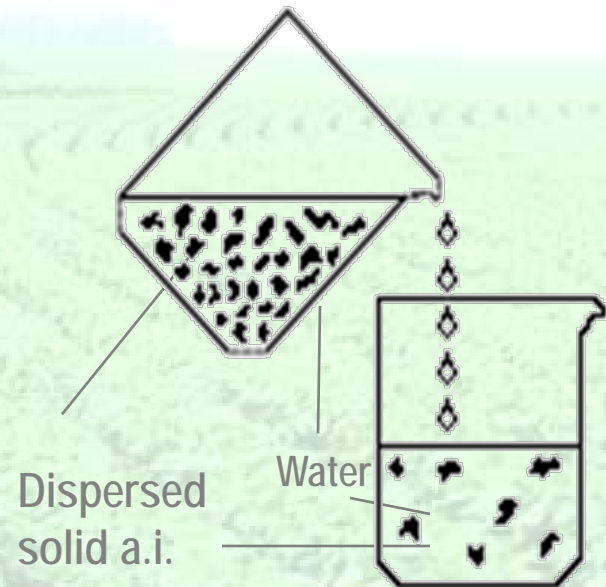

# Wettable Powders (WP's)

- AI blended with wetter, dispersant, anti-foam, and filler then milled to give a fine particle size.
- When added to water the powder is wetted and dispersed throughout the spray dilution

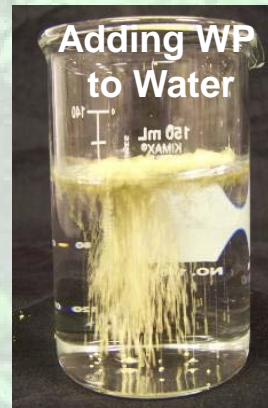
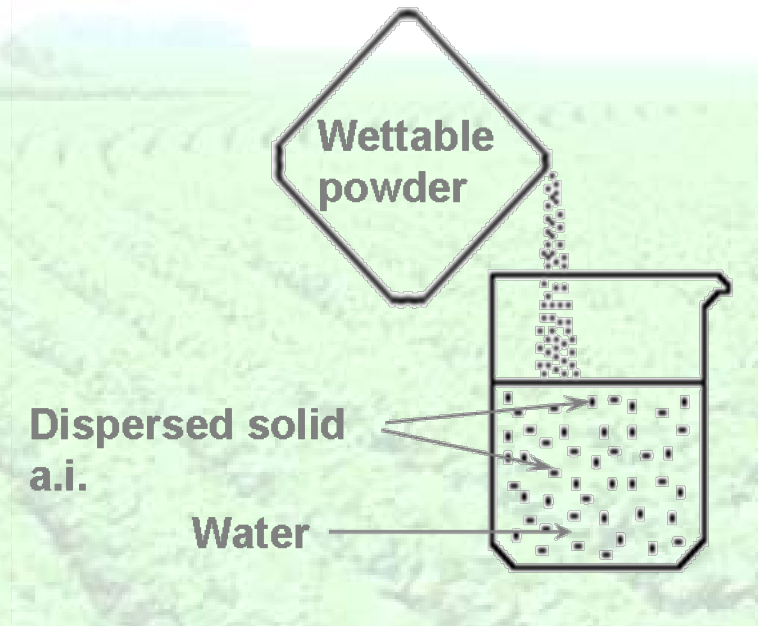

# Water Dispersible Granules (WG's)

- A.i. blended with wetter, dispersant, anti-foam, binder, filler and water – can be milled to give a fine particle size
- Granulation process
- When added to water, the granules break apart and form a suspension for application

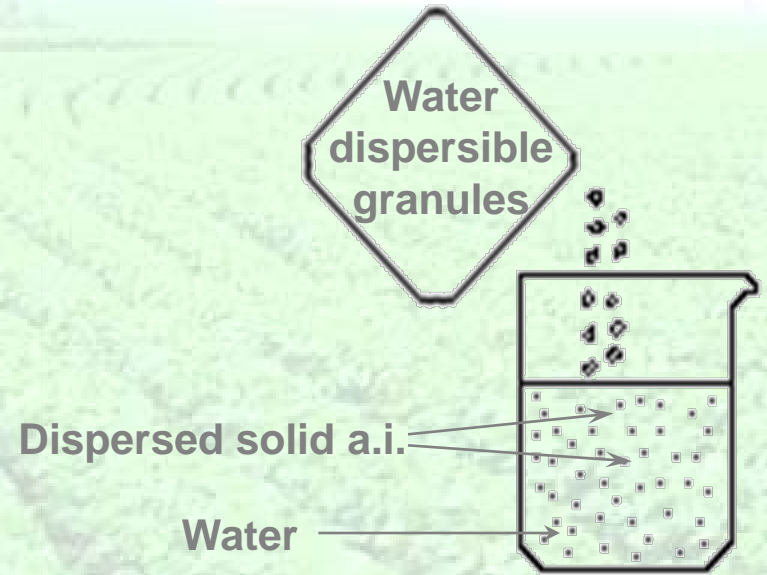

Upon stirring, WDG (or WG) spread into water spontaneously.



# Application Development

- Application Development (goal: ensure formulations are suitable for application in the targeted market and minimize launch surprises)
  - Storage
    - Characterize physical chemical properties under (or simulated) end-use conditions
  - Handling
    - Transferring, pumping, mixing, etc.
  - Applying
    - Dilution, spray, dynamic tank mix compatibility
    - Conduct researches in deposition, drift, penetration, uptake
    - Materials compatibility in related to application equipments
  - Cleaning out
    - Tank, boom, sprayer, container etc.

# Spray Characterization

- Spray pattern
- Drift reduction
- Wind tunnel
- Field trial



# Spray Nozzle

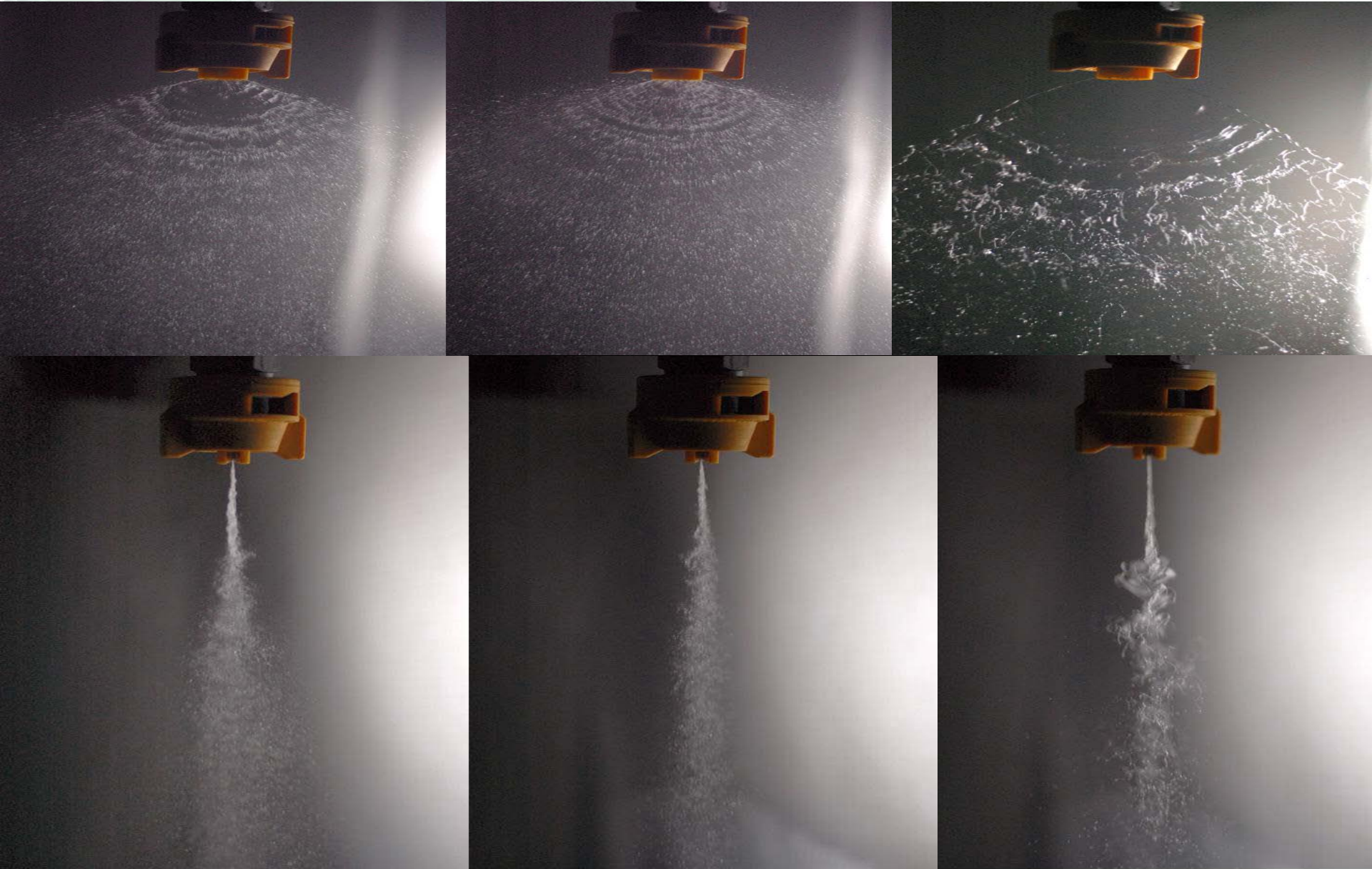

# Wind Tunnel



# Application Development

- Utilizes new formulation advancements to improve particle size distribution and reduce drift



# Active Manufacturing Typical Activities

Material Handling	Chemical Reactions	Product Recovery	Solvent Recovery	Waste Treatment
<ul style="list-style-type: none"> <li>- Storage tanks</li> <li>- Warehousing</li> <li>- Packaging</li> <li>- Ship &amp; receive</li> <li>- Raw material testing</li> <li>- Release testing</li> </ul>	<ul style="list-style-type: none"> <li>- Batch reactions</li> <li>- Solids, liquids, gases, catalysts, solvent / water based</li> </ul>	<ul style="list-style-type: none"> <li>- Distillation</li> <li>- Filtration</li> <li>- Extraction</li> <li>- Decantation</li> <li>- Crystallization</li> </ul>	<ul style="list-style-type: none"> <li>- Distillation</li> <li>- Filtration</li> <li>- Extraction</li> <li>- Decantation</li> </ul>	<ul style="list-style-type: none"> <li>- Thermal Oxidation</li> <li>- Neutralization</li> <li>- Carbon beds</li> <li>- Incineration</li> <li>- Biotreatment</li> <li>- Landfill</li> </ul>

# Typical Active Process Flow Diagram

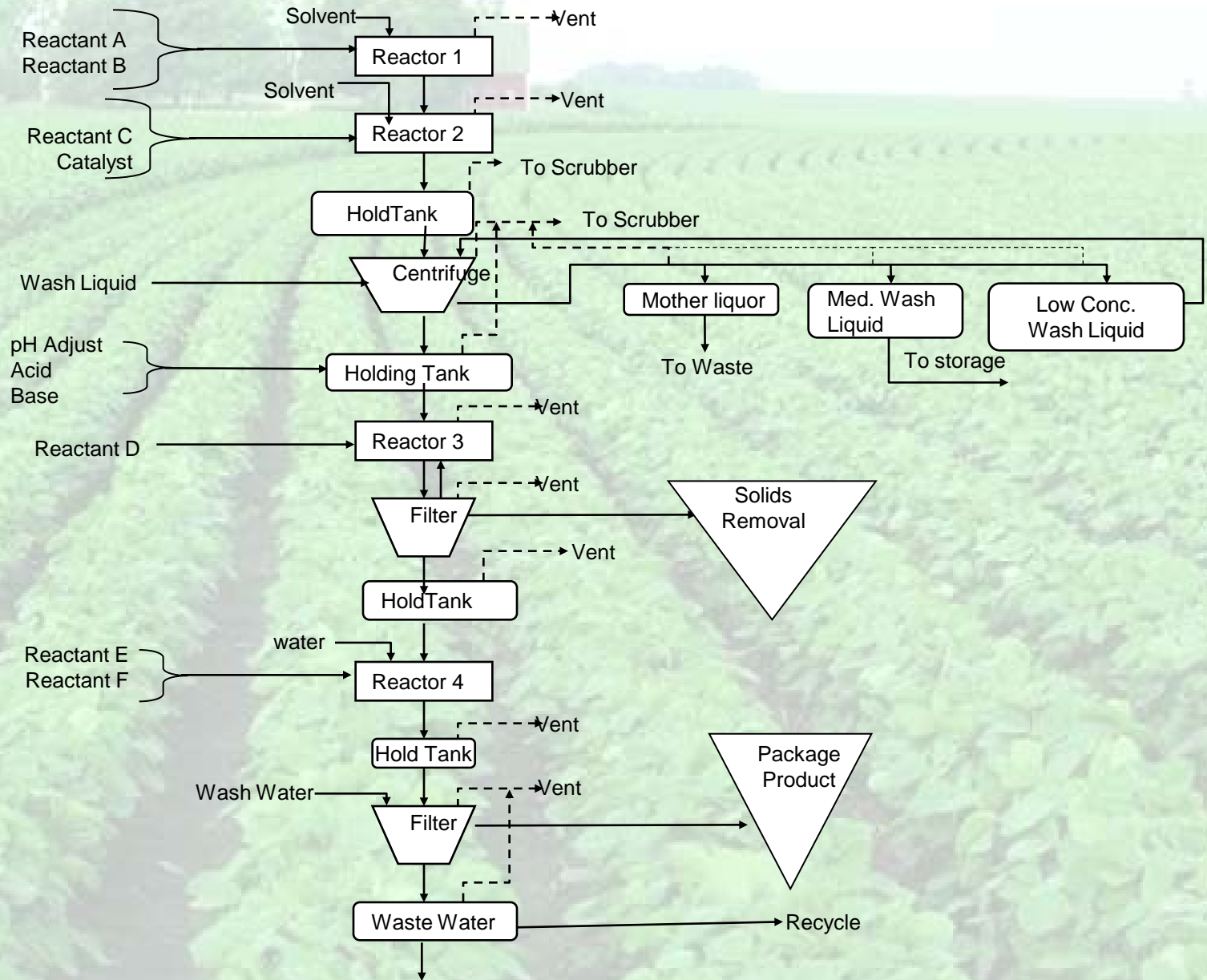

# Typical Amination Process

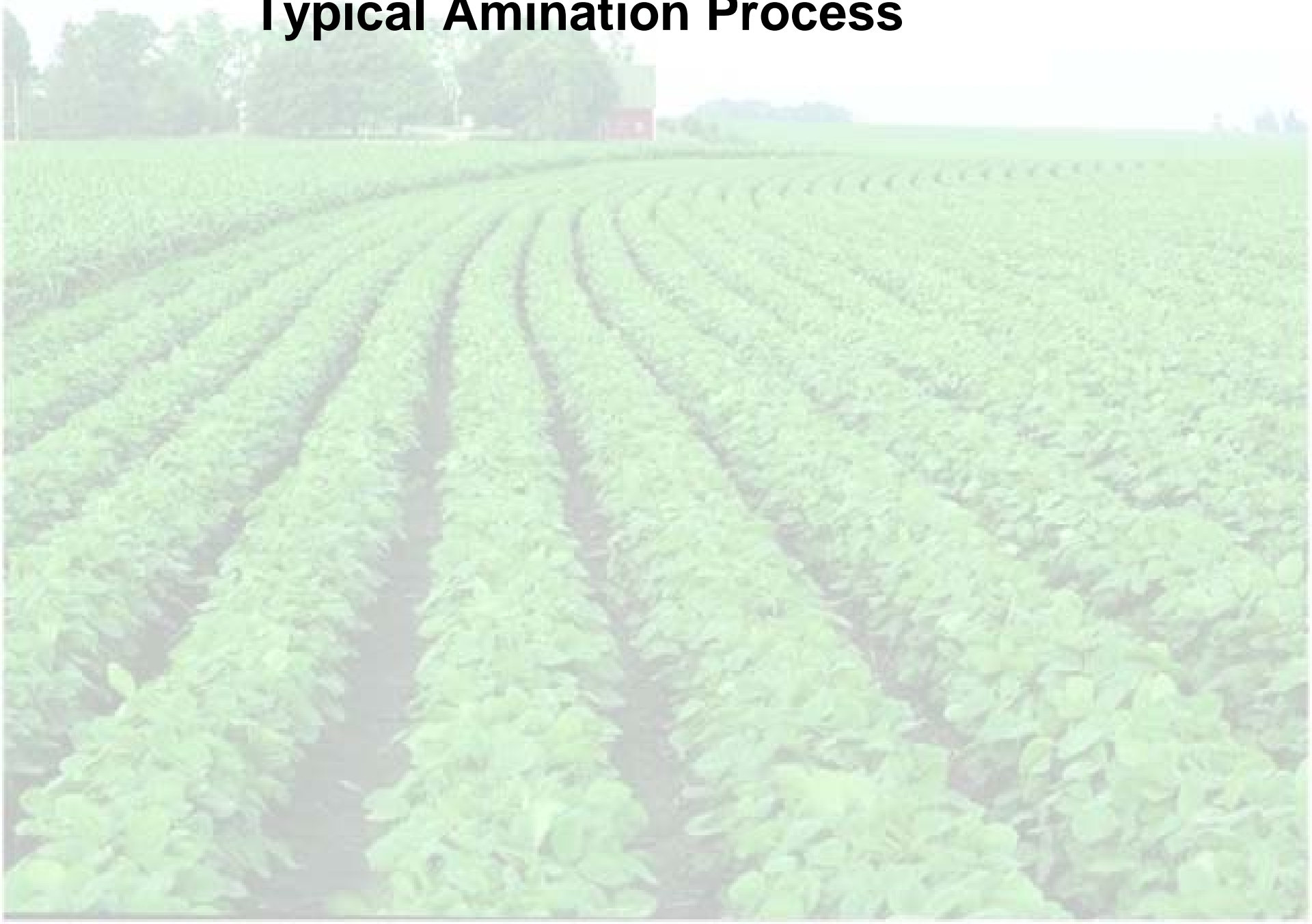

# Inside a Typical Glass-Lined Vessel with Agitator

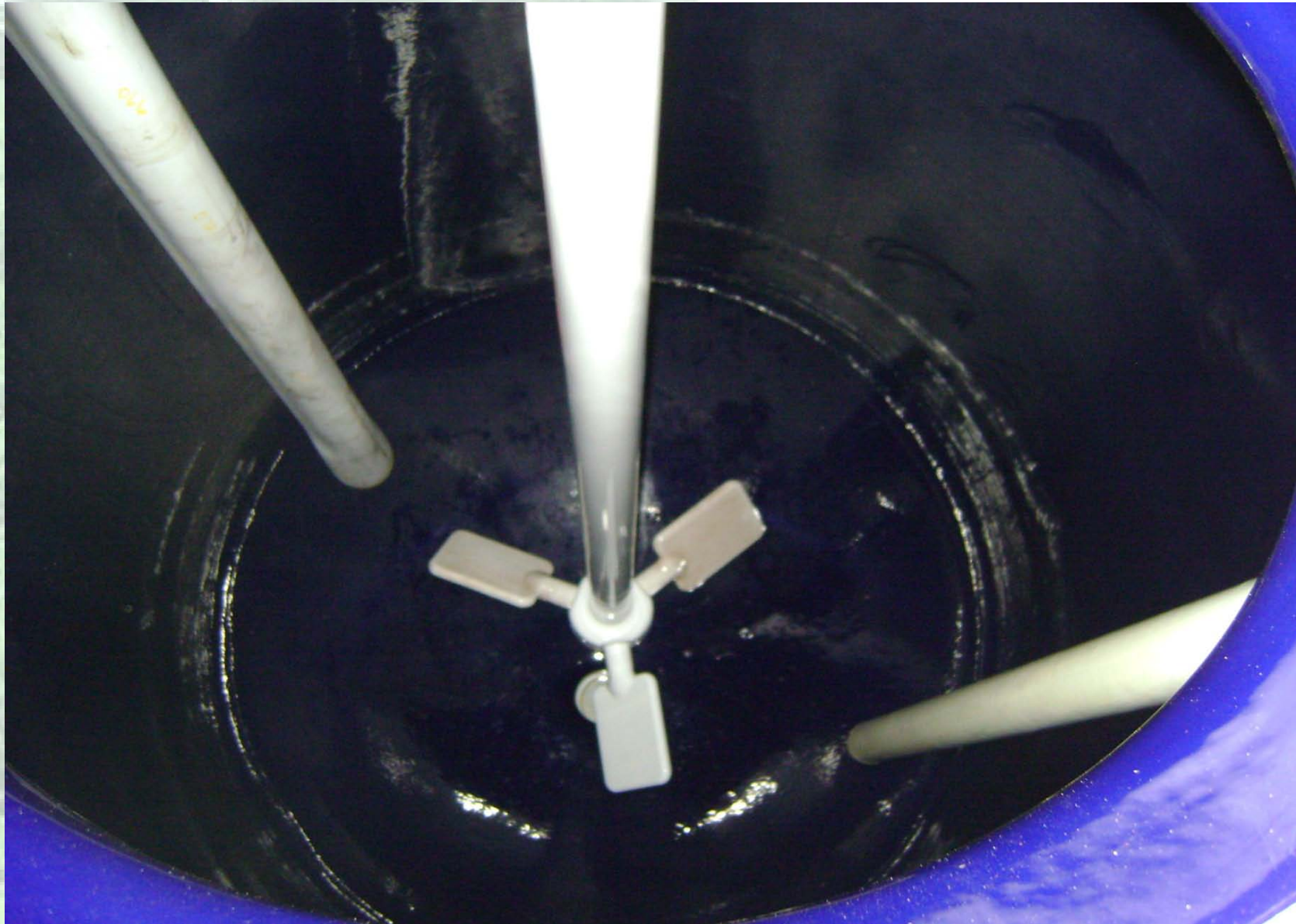

# Example of Batch Centrifuge



# Additives Plants

## Ethylene Glycol



# Formulation and Packaging

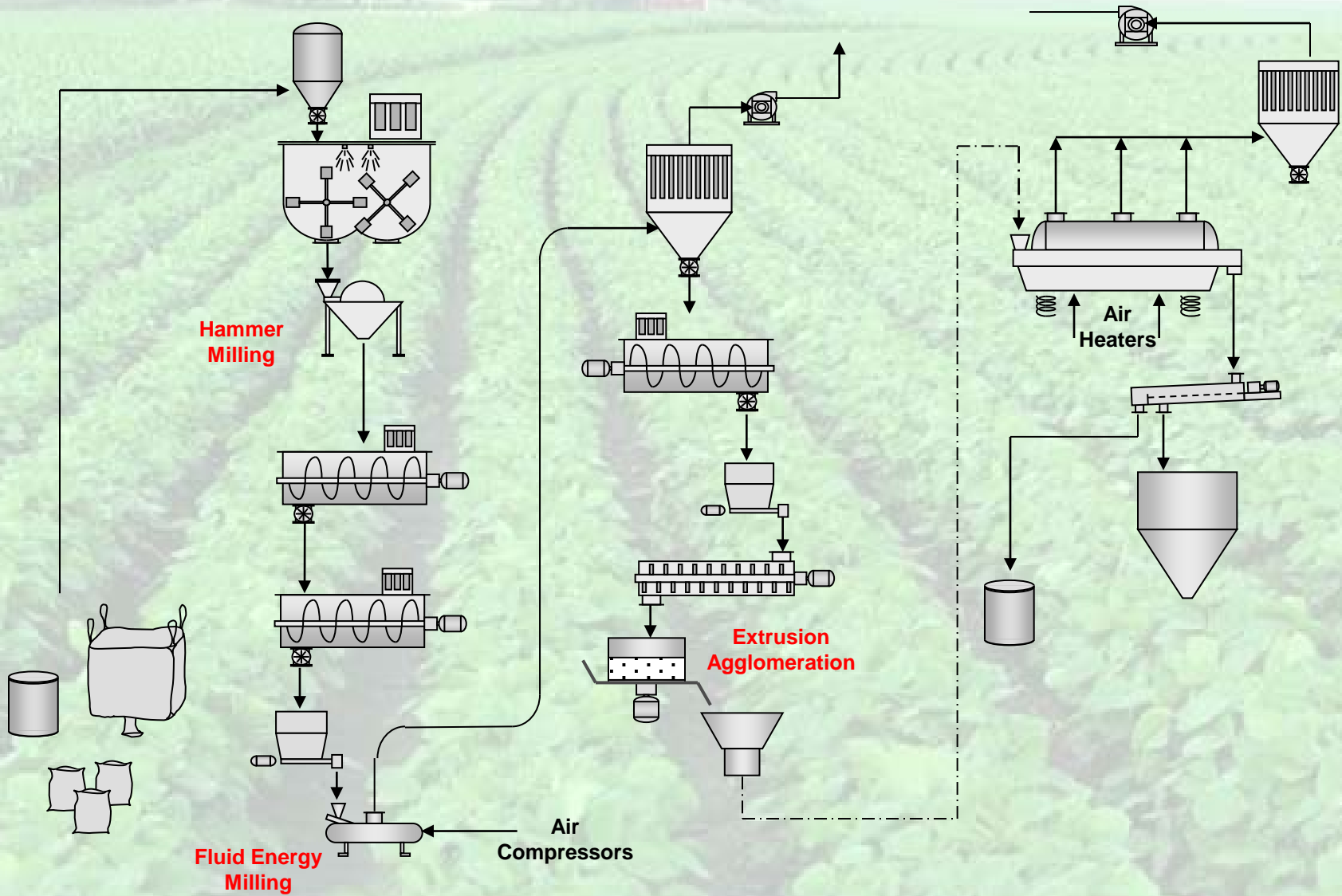

# Formulation and Packaging

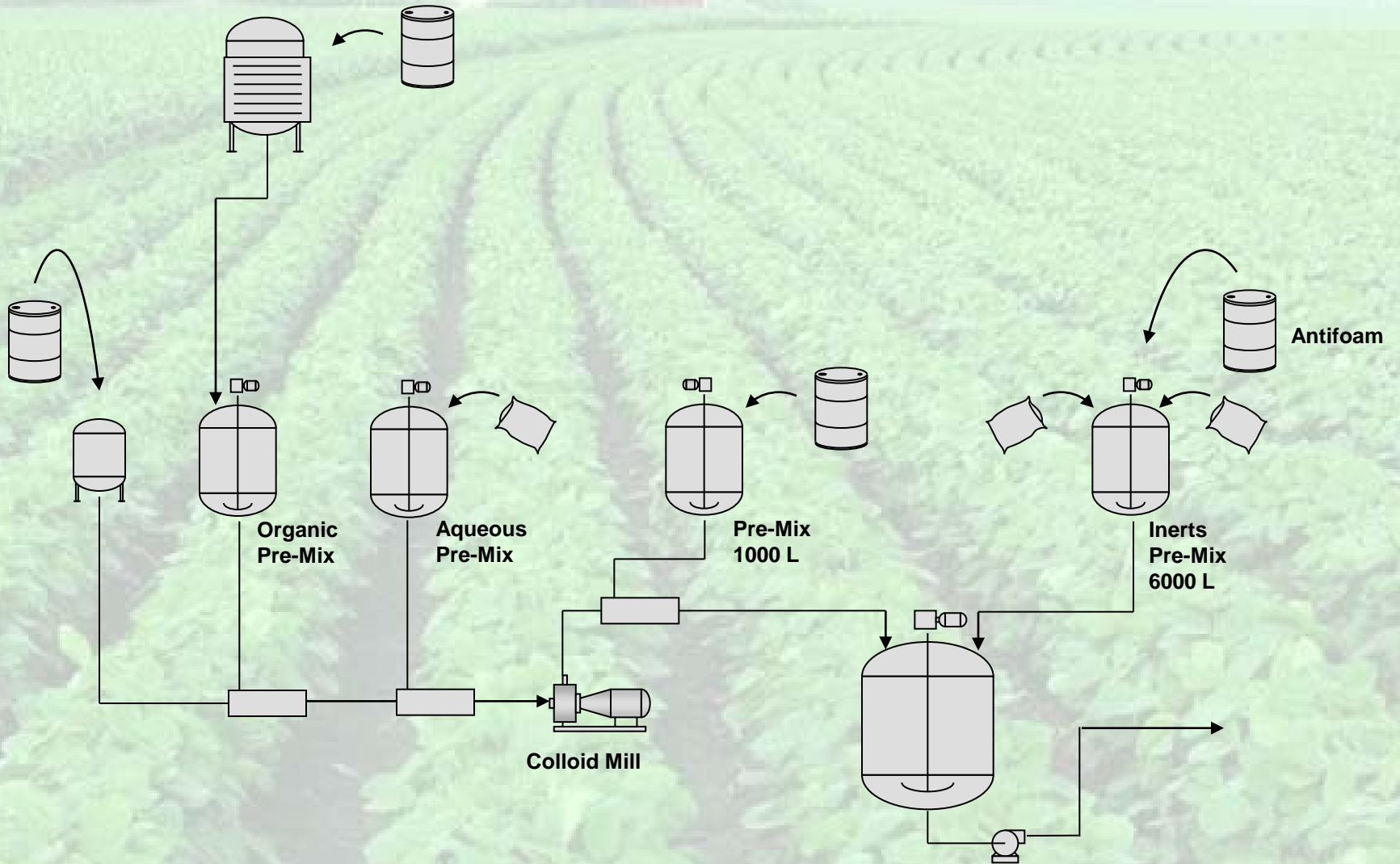

# Hammer Mill

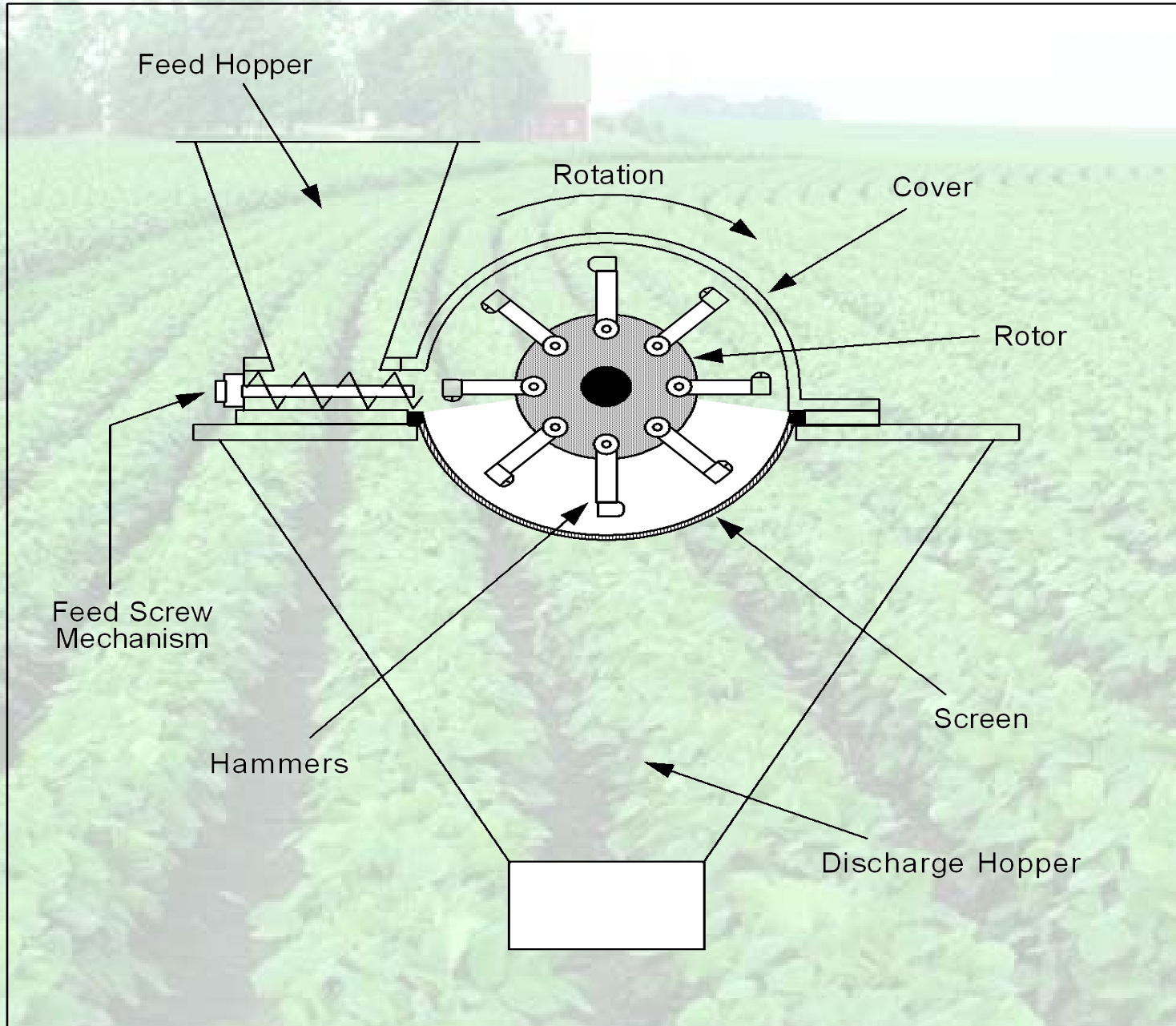

# Fluid Energy Mill - Air Mill

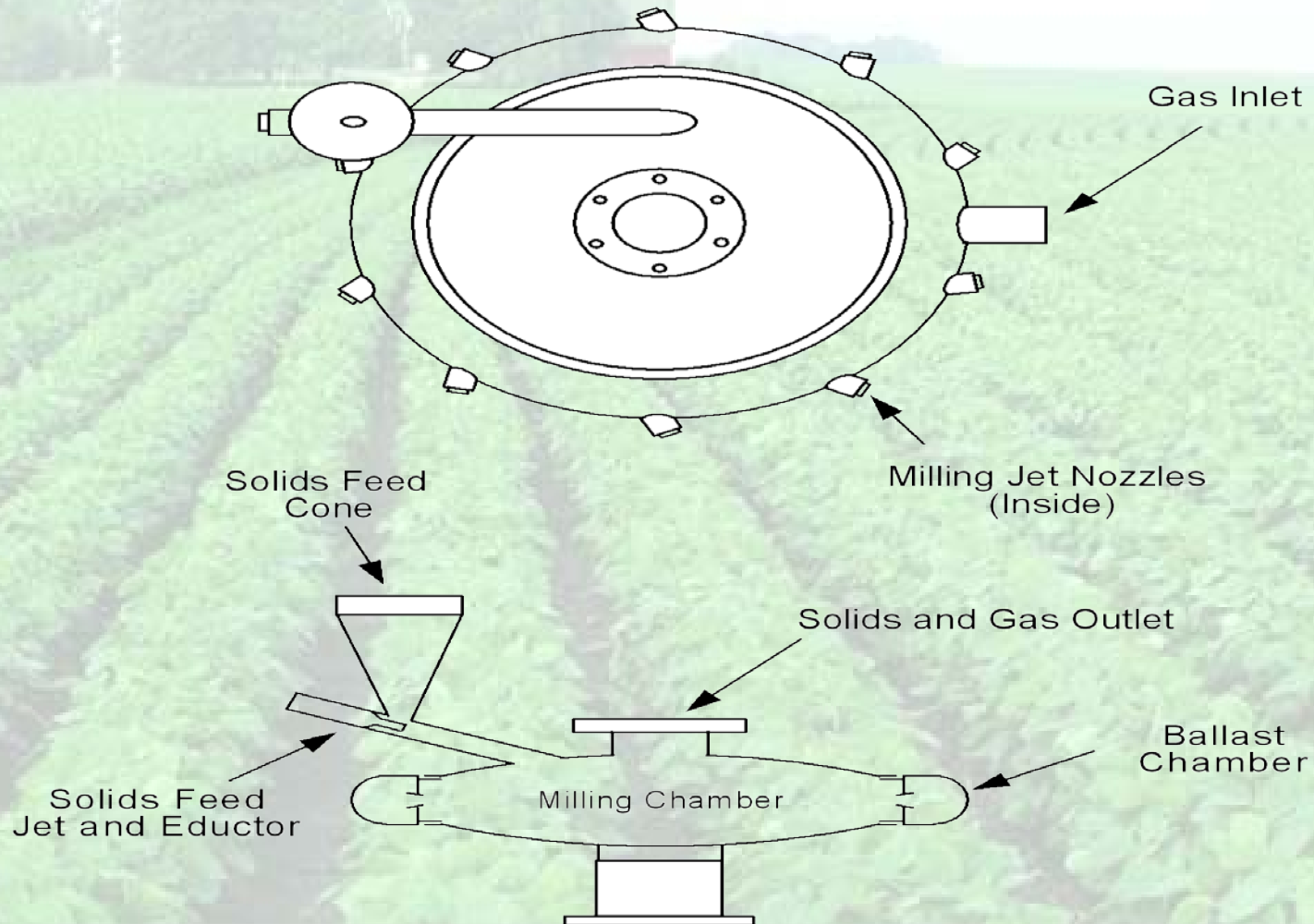

# Fluid Bed Agglomeration

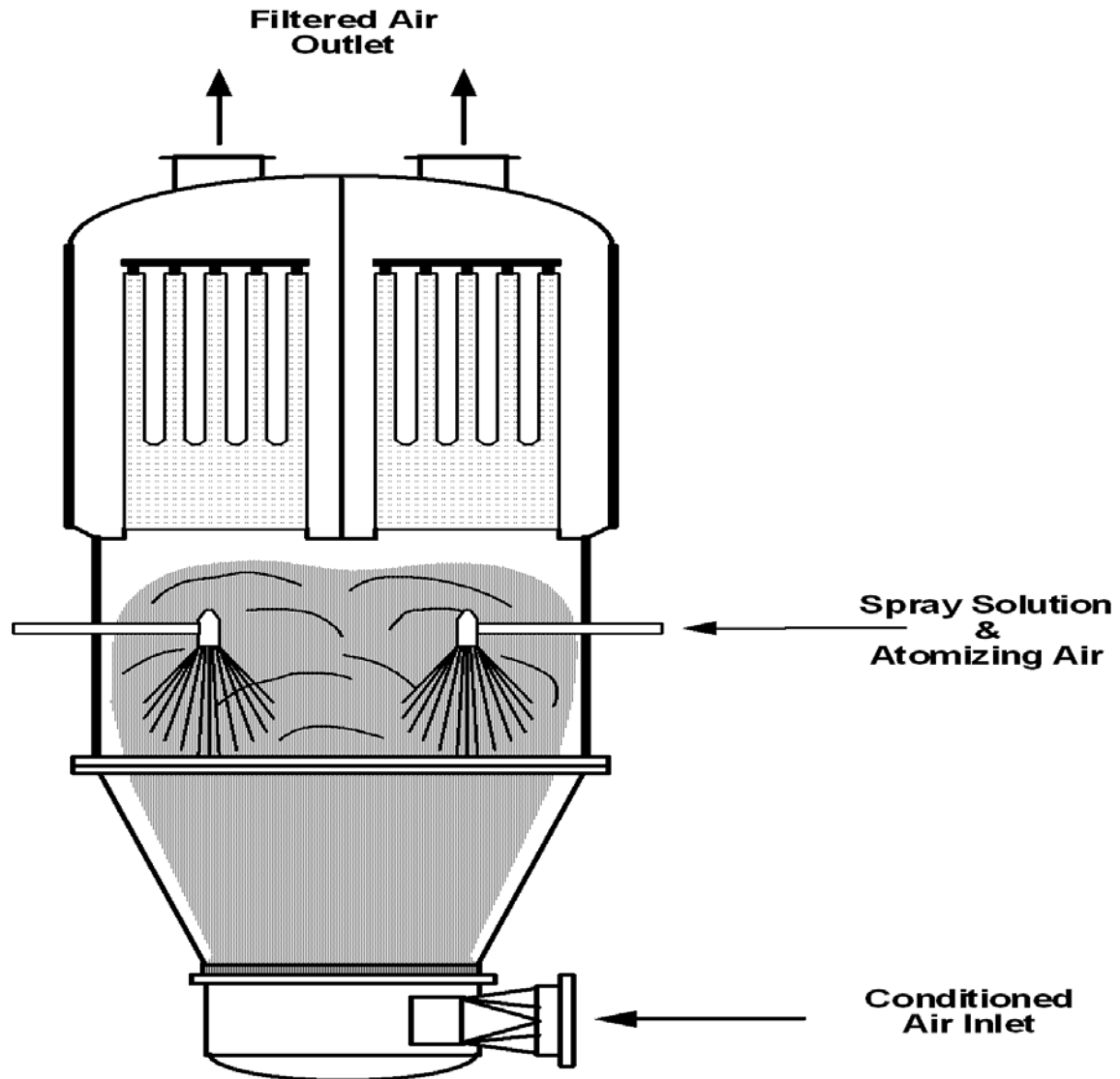

# Pan Agglomeration

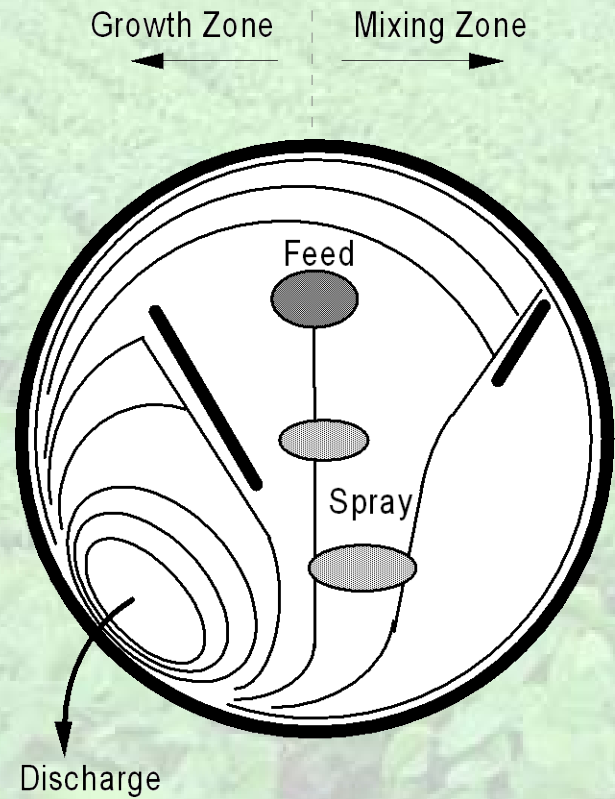
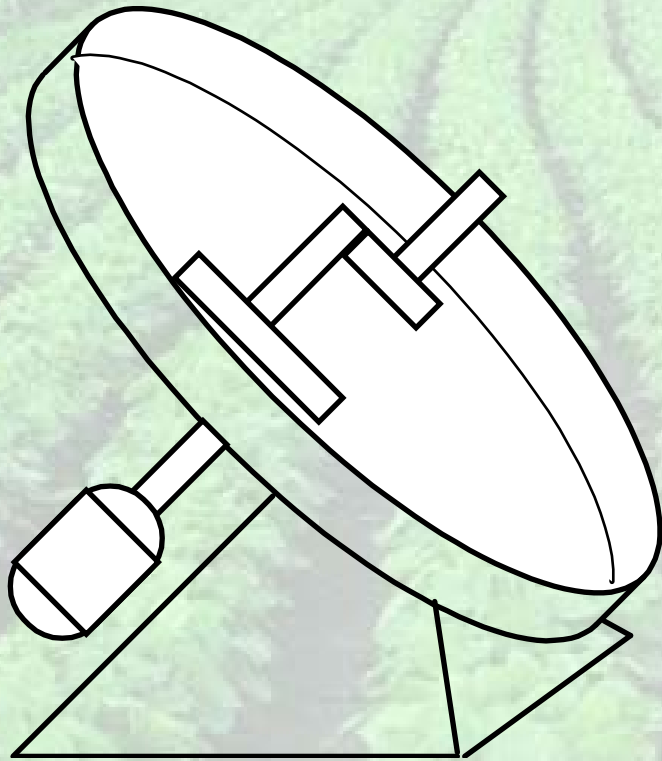

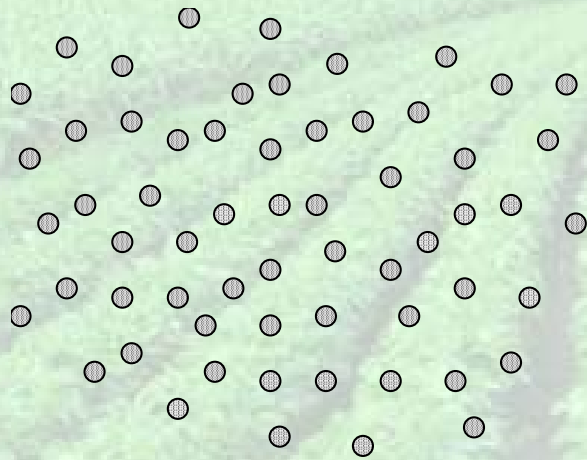

Wettable Powder

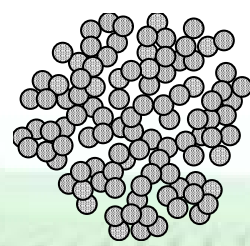
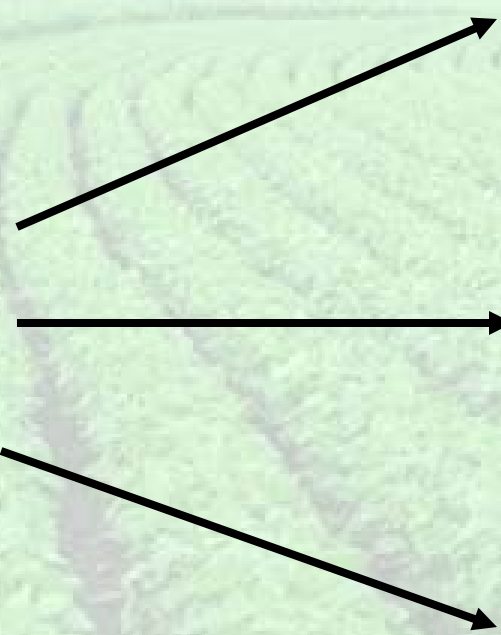

Fluid Bed  
Agglomeration

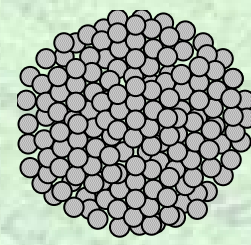

Pan  
Agglomeration

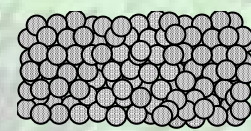

Extrusion  
Pelletization

Water Dispersible Granule

# Packaging Types

## Bottle in box

- Liquids
- Granular

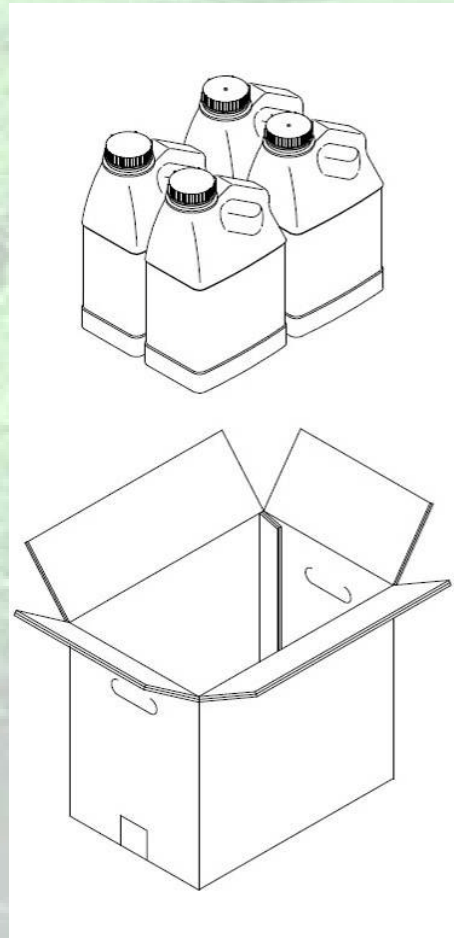
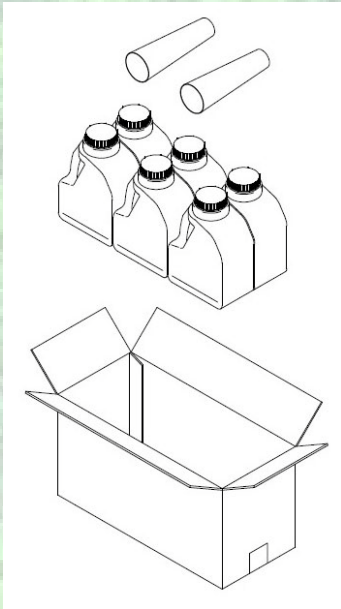

## Bag in box

- Dose packs
- Water soluble

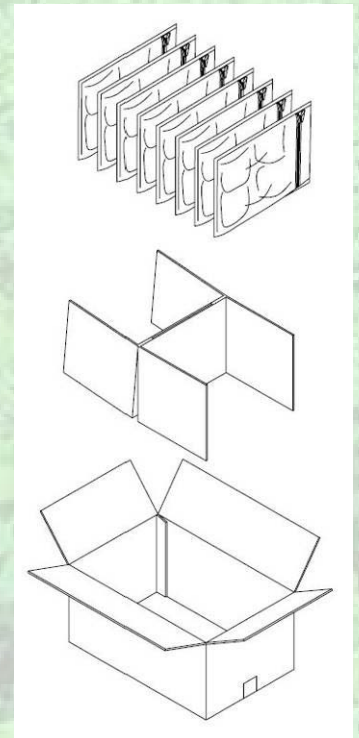
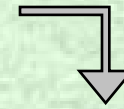
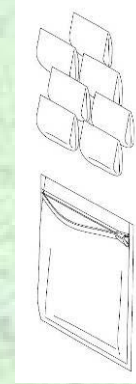

# Packaging Types

## Drums

- HDPE
- Steel
- Fiber



## FIBC

- Baffle, modular, Mega-base
- Liners – PE, Saranex



# Packaging Types

- Seeds

- Multi-wall bags
  - Sewn (stitched), Pinch (hot melt), Webb bag
- FIBC
- RIBC – Buckhorn Seed Box



# Packaging Regulations

- UN Certification / TDG / DOT compliance
  - Specified packagings
  - Hazard Labeling
- International Maritime Dangerous Goods (IMDG) Code
  - Reclassification of materials
  - New Marine Pollutant Logo – “Dead Fish, Dead Tree”
- EPA’s Pesticide Container and Containment Regulation (FIFRA 88)
  - Additional label requirements
  - UN Certified packaging for Restricted Use Pesticides
- Globally Harmonized System (GHS) of Classification and Labeling of Chemicals
  - Align Global Hazard Classifications, labeling and package requirements

A photograph of a vast agricultural field with rows of green crops, possibly corn, stretching towards the horizon. In the background, there are trees and a red barn under a clear sky.

***Thank You!***

***QUESTIONS?***